



AUTHOR
Isaac Frampton
Senior Staff Engineer

Identifying Load Management System Applications; Part 2 of 3

INTRODUCTION

Part one of this three-part series focused on appropriate applications of load management to help control load priorities and improve power quality to critical loads. This installment will explore setting up load-management systems, determining load priority orders and methods of shedding loads.

QUESTIONS TO ASK DURING LOAD-MANAGEMENT SETUP

While load-management setup is application-specific and depends on facility engineers to determine triggers to activate load management, there are four questions to answer in the process that are consistent for any setup:

1. Which loads need to be managed?
2. What is the load priority order?
3. How will the loads be shed?
4. How is load shed coordinated?

WHICH LOADS NEED TO BE MANAGED?

Load-management systems may prioritize loads based on the load type or importance. Load importance may vary widely depending on the application and facility, but often fall generally within one of the following categories:

Noncritical Loads

- Chillers
- HVAC compressors/pumps
- Elevators
- Luxury equipment such as swimming pools, hot tubs, etc.
- Office or commercial space

Important Noncritical Loads

These are loads that keep people comfortable and generally would not cause life-threatening situations if temporarily removed. Some common examples include:

- Air handlers
- Non-emergency lighting
- Medical imaging system

Critical Loads

These are loads that, if removed, could potentially cause life-threatening situations. Some common examples include:

- Generator support system such as fuel transfer pumps, louver controls and remote display panel alarms
- Emergency lighting
- Fire pumps

- Life-support system
- Safety equipment such as navigation or propulsion systems, air supplies, etc.
- Communication systems such as computer servers or telephone switchboards

WHAT IS THE LOAD PRIORITY ORDER?

The initial task for prioritizing load order is usually to determine which loads will have the least harmful effects when power is removed. The process of prioritizing loads could take some time, particularly where potential repercussions from shedding a load are not immediately evident.

For example, at first glance, air handlers may not be considered critical. However, if they are left inactive for long periods of time, the air may become stale in some environments and even toxic to breathe in other environments, therefore, causing the air handlers to become critical loads.

Another consideration when prioritizing a load order is to understand the whole power circuit path. While some critical loads may be immediately evident, additional loads required for operation of the critical loads may also need to be classified as critical loads. For example, while lights in an operating room of a hospital may be clearly categorized as a critical load, it may be important to remember that the electrical panel controlling the lights should also be classified as a critical load to ensure proper control of the lights when needed. When assigning load priorities, facilities engineers may benefit from following three steps: categorize, prioritize and review.

Categorize

1. **Interdependency** – assign priority based on most critically dependent system.
2. **Similar function** – loads may be grouped into a category based on which systems they support.

3. **Power Requirements** - when segregating loads, try to minimize the impact of shedding a single priority on the system to not require additional loads to be shed. When grouping loads into a priority, it is often useful to achieve a minimum shed, such as 20 percent of the rating of each generator. If the load shed exceeds 100 percent of the generator rating, it may be useful to split that into two load priorities. If not, the system may remove additional loads that otherwise could have been powered.
4. **Number of available properties** - the number of supported priorities in a load-management system will often determine the number of categories that can be supported and how broad the categories should be. While the number can vary between systems, a common rule of thumb is two load priorities per generator. Some load-management systems may not permit configuration of the expected load for each priority. In these cases, the load should not provide significantly more inrush loading than the fixed expected load per priority.
5. **Acceptable outage time** - some loads can be easily shed for several hours, but are necessary to operate occasionally. Acceptable outage time can be managed on some load management systems to allow periodic cycling of shed priorities.

Prioritize

Once the categories have been determined, it can be beneficial to assign a priority to each one by determining the criticality of each category. Below are some factors to consider:

- Applicable regulations
- Human safety
- Cost to productivity
- Out-of-pocket cost
- Effect on customers, company reputation
- Convenience

Review

After engineers have categorized and prioritized the loads, it may be useful to review and check the load groups for potential issues. Some common issues an engineer may encounter include:

- A more important category depending on a less important category
- Failing to identify categories with levels of importance that may change depending on the duration of the outage
- The difficulty of maintaining generators during an extended run since loads are often shed while generators are in need of service
- Inability to add priorities when other priorities are shed
- Downstream automatic transfer switches (ATS) that transfer from an unimportant load to an important load
- Distribution panel that has both critical and non-critical loads

HOW WILL THE LOADS BE SHED?

There are many ways to shed loads, but the following three methods are generally the most common:

1. Use programmed transition transfer switches, placing the switch in the OFF position.
2. Use breakers or contactors that can be opened and closed as needed.
3. Through equipment controls such as building-management systems, HVAC controllers, motor controllers, lighting controllers, dry contact or sending a message through a communication device, etc.

When a load sheds, some load-management systems may require a manual reset while others may reset automatically when another generator comes online, and some may not require a reset at all.

The reset requirement may provide advantages, such as providing a lockout to prevent unwanted load cycling and drawing attention to the shed condition. The lockout may also be instrumental in the detection of configuration errors.

Reset requirements may be disadvantageous in some cases as well, such as where generators could have easily supported some loads that remain shed while awaiting user interaction.

HOW ARE LOAD SHEDS COORDINATED?

Loads may have a very high initial power requirement that tapers off as the load reaches an operating condition. To avoid unintended cycling of load priorities, it is often beneficial to configure the expected load of each priority as the maximum load that the priority could add to the generator system.

Each generator and application is different, so it is typically important to ensure that the load-management settings are configured to shed load before the generator controller shuts down or a protective relay trips the generator paralleling breaker.

Finally, systems that incorporate generator management should generally be configured so that any disconnected but available generator will start and connect to the paralleling bus before loads are shed, except during an abnormal overload.

OTHER FACTORS TO CONSIDER?

System Redundancy

In many applications, generators are paralleled to allow for redundancy and prevent a single point of failure. If a load-management system is used, consideration for redundancy and failure of the load-management functionality should also be evaluated.

Load-management redundancy can be provided to varying extents:

- Control redundancy
- Shed redundancy
- Supply redundancy
- Manual control override

Control redundancy provides an alternate method of controlling some or all of the load control priorities when any single device loses primary functionality, power or communication. In cases where the generator controller is providing the load management functionality, it may be helpful to tie some load priorities to each of the controllers to retain partial functionality when a generator controller is disabled, avoiding a single controller failure that otherwise could result in a loss of load-management capability on a system. Many discrete load-management systems provide integrated redundancy with varying degrees of integrated redundancy (from dual processor to dual power supply to fully redundant system with duplicate controllers).

Figure 1 represents an example system, where four generators are paralleled to a common bus. The bus supplies power to nine segregated loads. The loads are prioritized as critical, never to be shed, and numbered 1 through 8, with 1 being the most important. Through the load-management system, priority loads 1 through 8 will be added and removed as needed. In *Figure 1*, each generator controller offers load management to two loads. If the load-management system fails, the loads will automatically be powered from the bus.

Figure 1

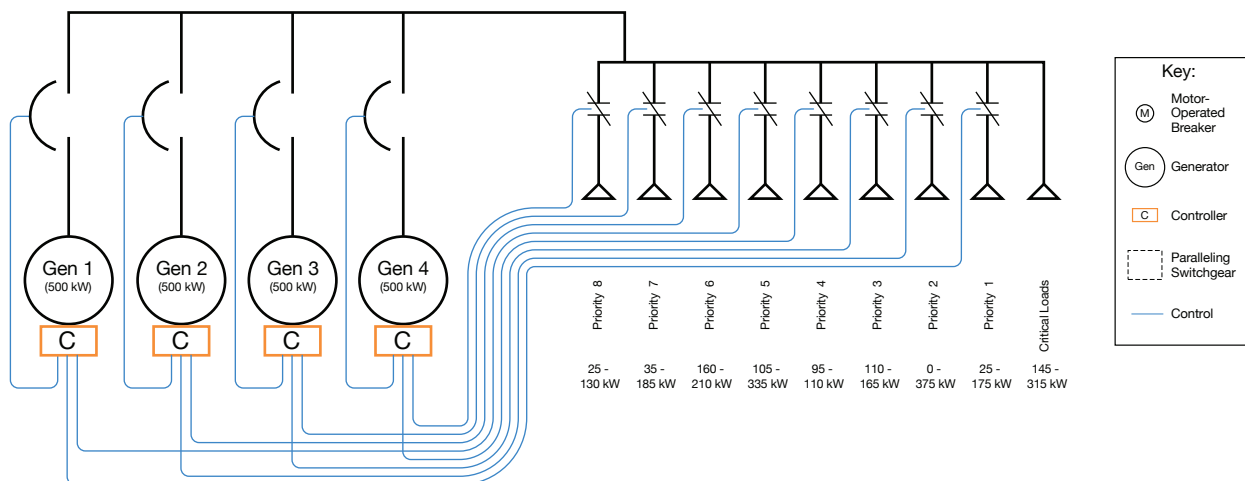
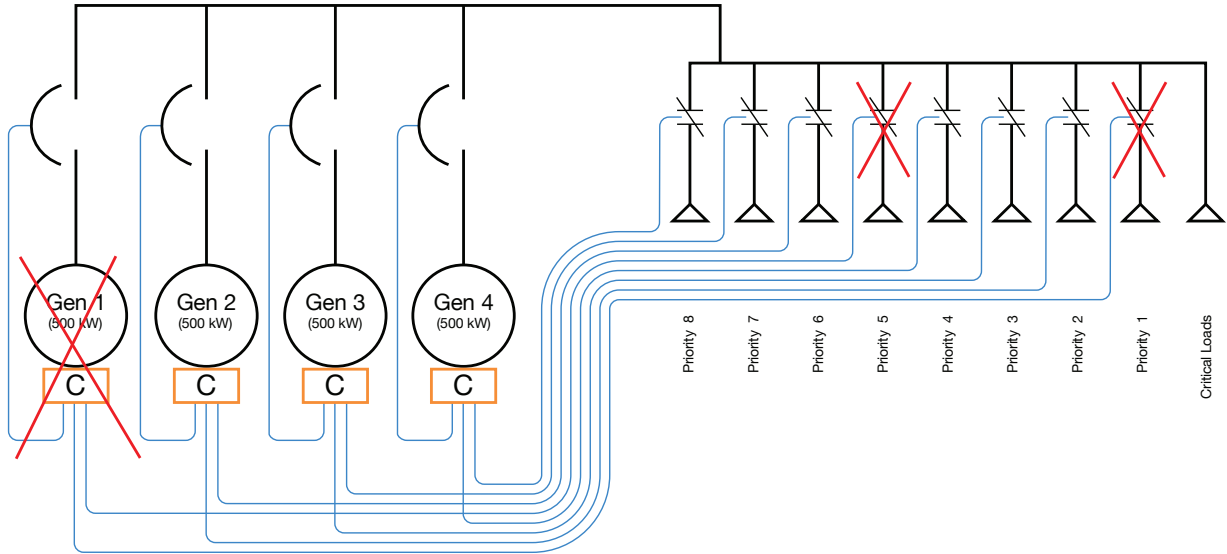

Figure 2



In *Figure 2*, each generator controller provides a portion of the load-management functionality.

Loss of a generator controller will only result in the loss of control of two priorities, giving the system some capability to maintain power to critical loads. The loads controlled by generator 1 are added to the bus. Priorities 1 and 5 cannot be shed due to generator 1's failure; however, the other six loads can still be shed.

If the load management for the entire system was provided by the controller for generator 1, as shown in *Figure 3*, all the loads would be added if that controller was powered down to perform service on generator 1.

Figure 3

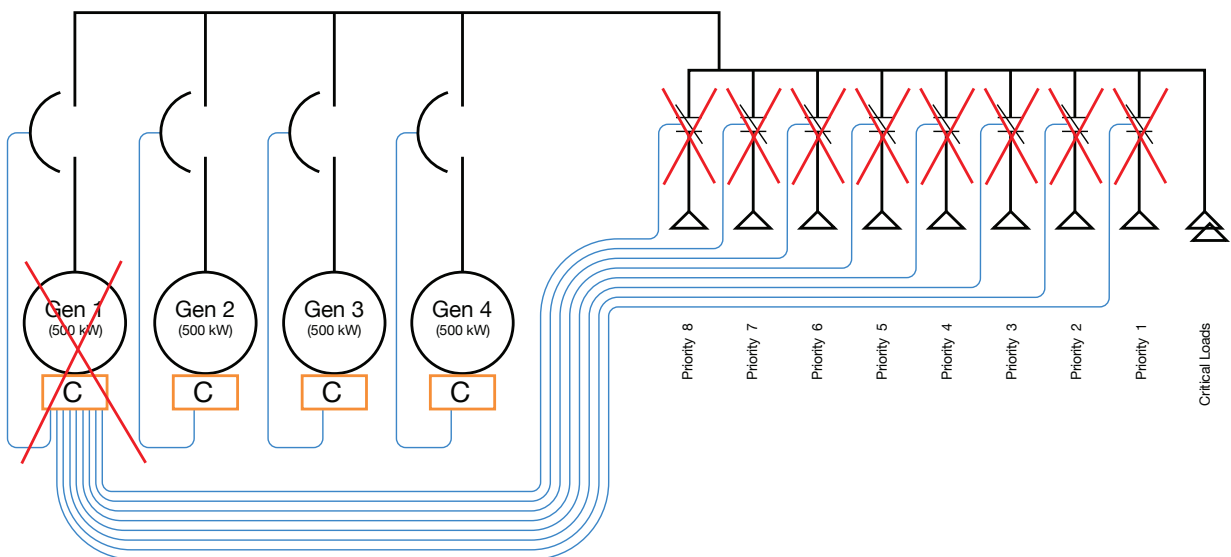
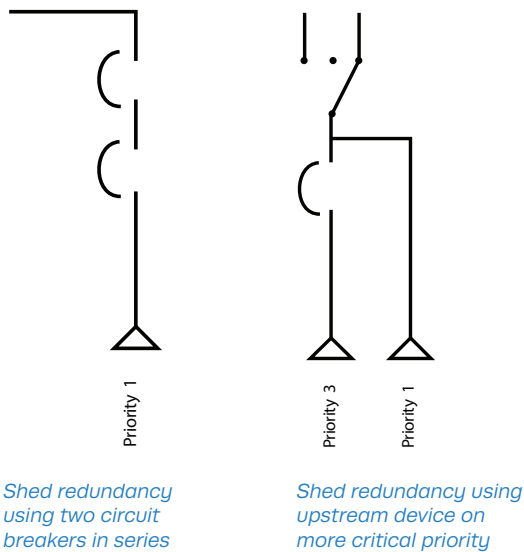

Figure 4



Shed redundancy provides multiple means to disconnect a priority. In some cases, shed redundancy is provided by two circuit breakers in series. In other cases, it can be provided by interrupting an upstream switch in the event of a failure. The upstream switch is often tied to a more critical priority, which still provides the function of providing redundancy for shedding the less critical priority, but only allowing a single means to disconnect the more critical priority. Shed redundancy is often provided when the means of shedding a load is perceived to be unreliable, such as sending a shed signal over a communication network, or when shedding the load is considered highly important. *Figure 4* shows an example of shed redundancy.

Supply redundancy is essentially the opposite of shed redundancy in that it allows for two sources to feed the load, requiring that both sources are shed to remove power to the load. Supply redundancy is commonly used in applications where inadvertent shedding of a load could result in highly undesirable conditions. If consideration is given to supply redundancy for a load priority, it may be beneficial to also consider the possibility of increasing the individual size of the supplying generators and including the load with the critical loads.

Use of a programmed-transition ATS to provide load-shed capability may provide supply redundancy by default, as most ATS controllers will not shed load when fed by the normal source. In addition, many ATS controllers will also automatically transfer from the load-shed position to the normal source in the event of a return of normal power. *Figure 5* shows an example of supply redundancy.

Figure 5

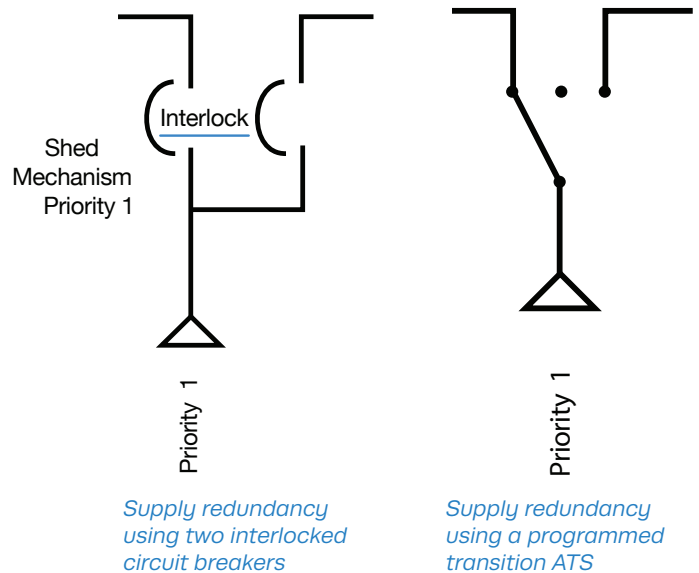

Manual control override can provide a versatile, inexpensive and robust means of providing redundancy. An operator can make decisions based on factors that are unknown to the load-management system, can operate devices that are no longer able to operate electronically and can diagnose the cause of a failure. Manual control override may provide redundancy quite effectively in applications where a facility has full-time maintenance staff, but maintenance personnel may not be able to respond in a timely manner to a failure in a remote location.

Manual control override can be implemented on a variety of levels. Some load-management systems provide a user interface to allow manual override of the automatic system, but the user interface may only provide a means to temporarily change the system functionality (and thus not provide redundancy). The enhancement to system redundancy provided by a manual control override typically improves as the override is moved closer to the actual switching hardware for shedding the load.

Fail-safe operation

Even when redundancy is not provided in a load-management system, it may be important to specify how the system will behave when the load-management capability fails. There are two primary choices: failure that results in the load always being powered (normally added) or failure that results in the load never being powered (normally shed).

For standby applications, load priorities can typically be configured to be normally added if the load-management system fails. In standby applications, loads are usually connected to utility, and the power generation system is used in emergency situations only, so it may be useful to retain power to the loads.

For prime power or low utility reliability applications, loads may often be configured to shed with a failure. Since these systems are typically on the generator, it is important not to overload the generator and potentially cause the entire system to shut down leaving all loads with no power.

Use of a programmed-transition ATS as a means to interrupt power to a load may provide the best of both worlds, as it generally will not shed load while on the normal source (even if it gets an erroneous shed signal), but it should interrupt the load if fed by the emergency source. Load priorities that are shed using a programmed-transition ATS can be configured to shed the loads if the load-management system fails, minimizing the chance of generator overload in the event of a load-management system failure, while still preventing the risk of unintended outages while fed by utility.

Regardless of the selection for fail-safe operation, it is important to take care when planning power supply, control wiring and control reliability for any devices that control the power supply to a load.

The next and final installment of this three-part series will explore seven methods for load management.

ABOUT THE AUTHOR



Isaac Frampton is a Senior Staff Engineer at Rehlko Co. He has worked for the company's Rehlko Power Systems division since 2006 and specializes in control system design and paralleling applications. He has a bachelor of science in electrical engineering from Kettering University in Flint, Michigan.

ABOUT POWER SYSTEMS

Power Systems, Rehlko's largest division, delivers worldwide energy solutions designed to ensure resilience for mission-critical applications of all sizes. Building on more than a century of expertise and dedication, the company offers complete power systems, including industrial backup generators (HVO, diesel, gaseous), enclosures, hydrogen fuel cells systems, automatic transfer switches, switchgear, monitoring controls, genuine parts and end-to-end services. As a global company with service partners in every country, Power Systems provides reliable, cutting-edge technology to keep industries and businesses running.

www.powersystems.rehlko.com

ABOUT REHLKO

A global leader in energy resilience, Rehlko delivers innovative energy solutions critical to sustain and improve life across home energy, industrial energy systems, and powertrain technologies, by delivering control, resilience and innovation. Leveraging the strength of its portfolio of businesses – Power Systems, Home Energy, Uninterruptible Power, Clarke Energy, Heila Technologies, Curtis Instruments, and Engines, and more than a century of industry leadership, Rehlko builds resilience where and when the grid cannot, and goes beyond functional, individual recovery to create better lives and communities, and a more durable and reliable energy future.